

# Staying Home Corporation

2501 Anaconda Road  
Harrisonville, MO 64701  
816-380-2427  
www.stayinghome.com



## Model SL19 Installation Manual

April 10, 2023

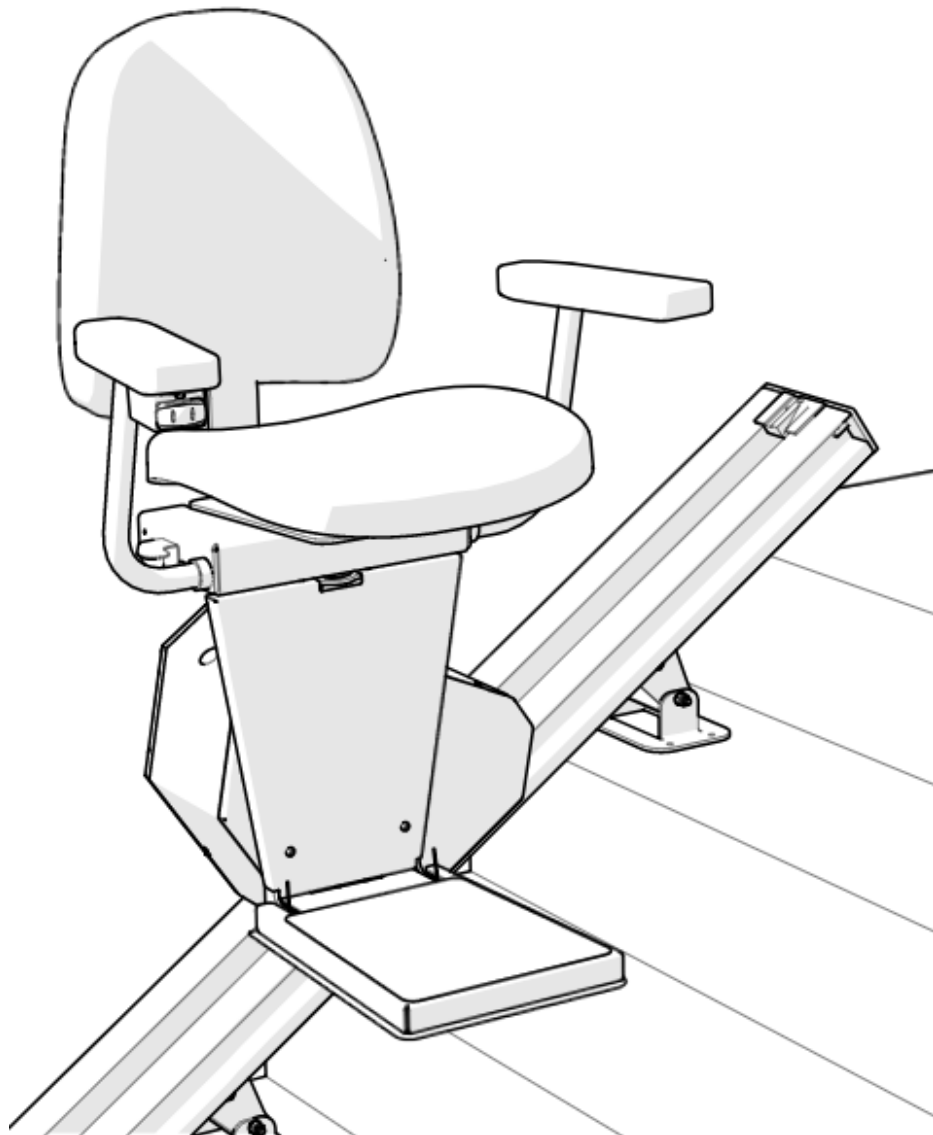

## Preliminary Checks

### Installation Site Requirements

- \_\_\_ 120 VAC, 60 Hz, 3-wire grounded outlet within 6' of the top of the staircase.
  - \* Some states may require dedicated outlet.
- \_\_\_ Stair angle between 25° and 45°.
- \_\_\_ Indoor installation.

### Included with Shipment

- \_\_\_ Aluminum track with gear rack and splice bars
- \_\_\_ (4-6) Track mounting brackets
- \_\_\_ Chassis
- \_\_\_ (2) Plastic cams
- \_\_\_ Footrest
- \_\_\_ Seat
- \_\_\_ Battery Charger with 6' cord
- \_\_\_ Header cover
- \_\_\_ Upper and lower track end caps
- \_\_\_ (2) Wireless call/send key fobs
- \_\_\_ Small parts bag
- \_\_\_ Installation Manual
- \_\_\_ Owner's Manual

### Tools Required

- \_\_\_ Set of nut driver bits
- \_\_\_ Set of screwdrivers (phillips)
- \_\_\_ Tape measure
- \_\_\_ 3/8" reversible drill w/8" extension
- \_\_\_ Allen wrenches
- \_\_\_ Portable band saw or hack saw  
(for cutting stock track)
- \_\_\_ Small level
- \_\_\_ Combination wrench (7/16" & 1/2")
- \_\_\_ Tools to remove handrail if interferes  
with the travel of the stair lift

## Typical Components

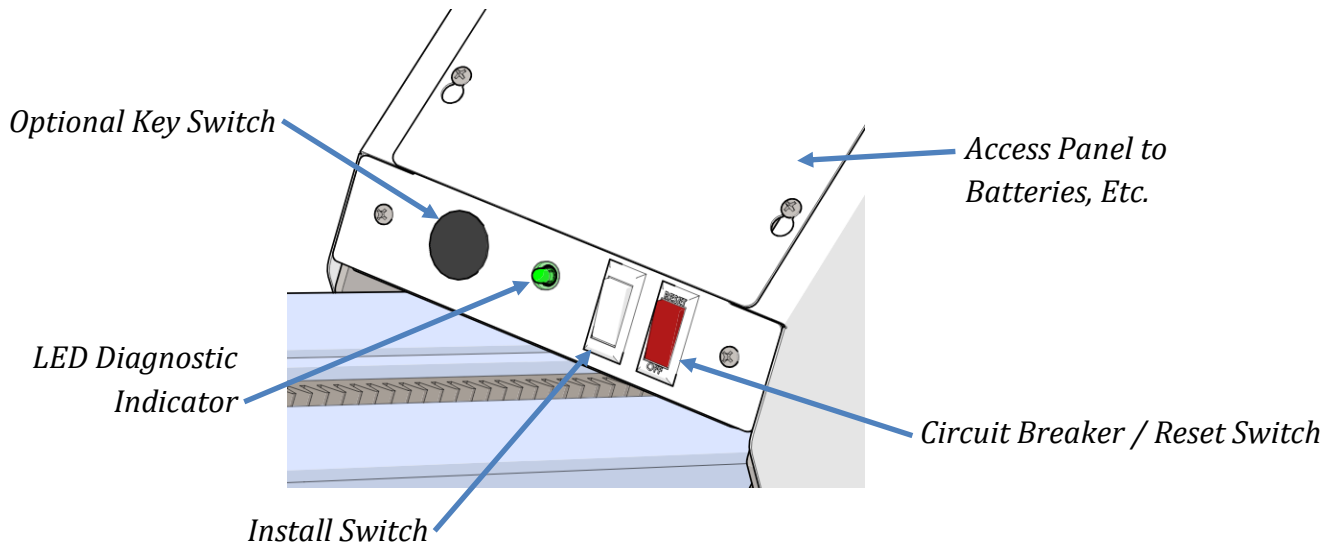
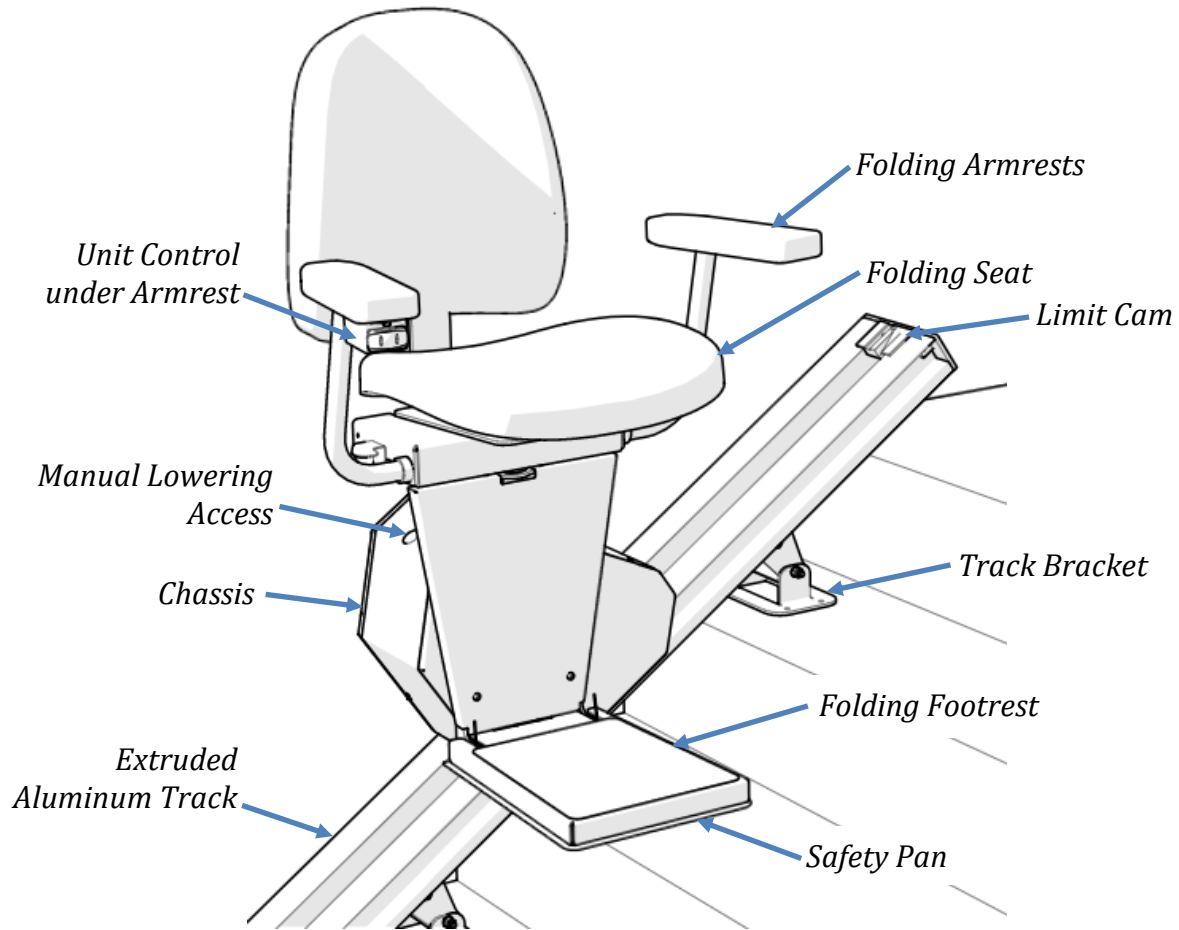

## Underside of Chassis

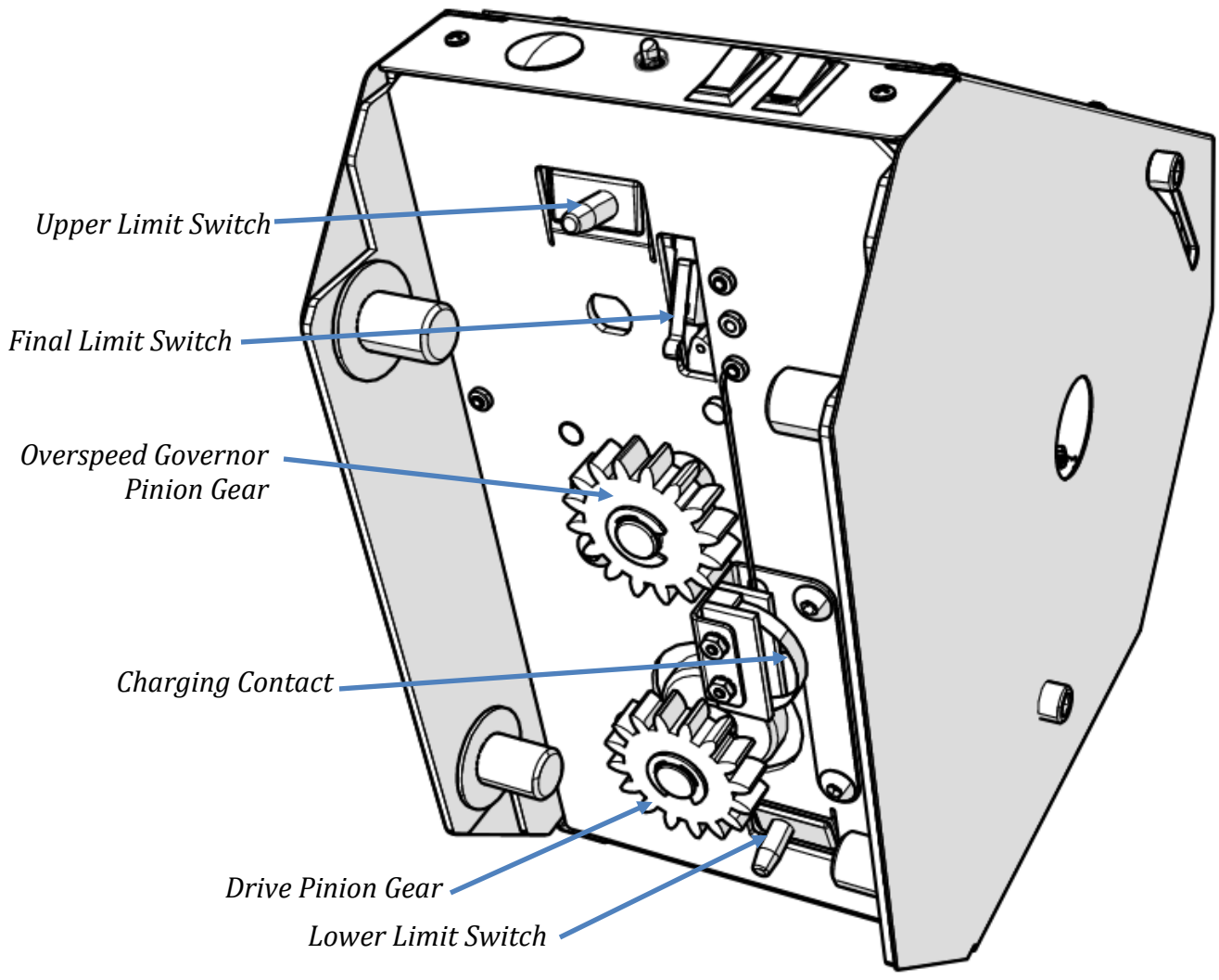

## Identify Track Pieces

Red paint on the end of the gear racks indicates that end has been precision machined. Only butt-up the ends of gear racks that are red. If the end is not painted, it must be put toward the end of the track.

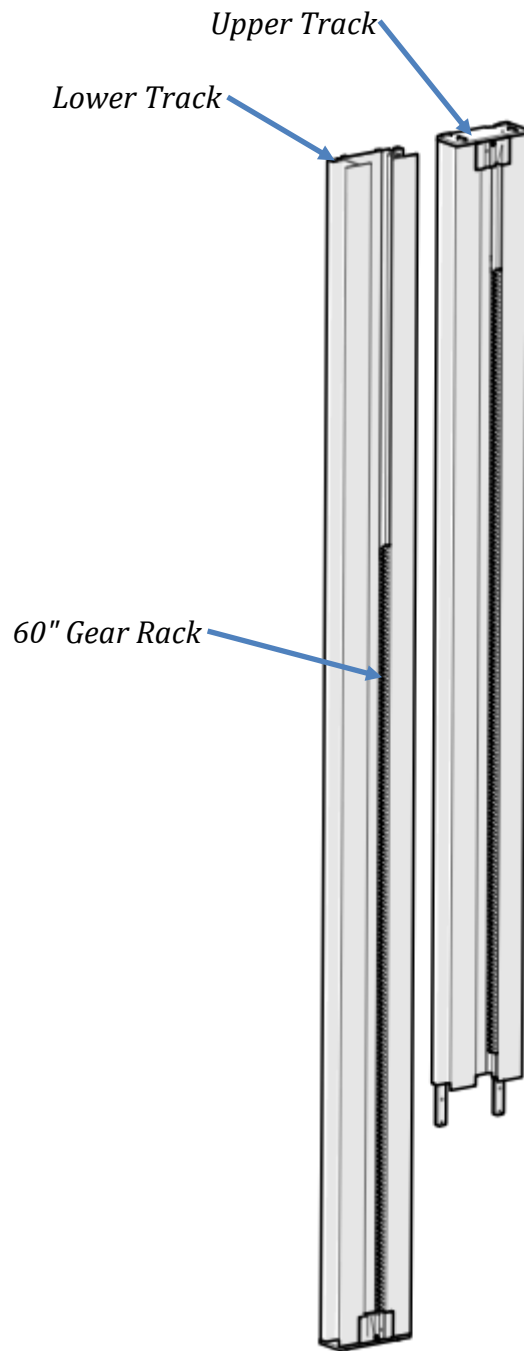

## Installation Procedures for Stock Units

**Track Installation:** Track and rack should be cut **before** installing them on the staircase

If your track was factory cut, skip ahead to page 7.

Tracks are packaged in individual boxes. You will generally have 2-3 sections of track with steel gear rack, (4-6) track mounting brackets located in a small parts box located in seat box, and 1-2 sets of splice bars already pre-mounted on the track.

**Note:** The upper and lower ends of the track sections are marked top & bottom. *The gear racks and charge strips are already inserted in the track.*

Look up the stairs and determine if the track is to be installed on the left side or right side. The gear rack should always be located on the right side of the track regardless of which side of the stairs the track is mounted.

Measure the distance from the top nose of the staircase to the bottom floor and add 7" (*note: be sure to verify clearance from top nose to any obstruction at the top such as a door or door frame that would cause the chair to hit or block the seat from swiveling.*) It may be necessary to ramp the track away from the obstruction, consult factory for assistance if needed.

**Note:** The minimum track length for the upper track is 38". If your total track length is less than 128", you need to cut an amount off the bottom end of the lower track to compensate for the 38" upper track. *If the upper track is less than 38", the track splice pin will interfere with the charge strip.*

Do not cut through the charge strip, remove or slide it out of the way. Cut the track at the top, leaving the factory cuts at all other sections.

Cut the gear rack flush with the top of track.

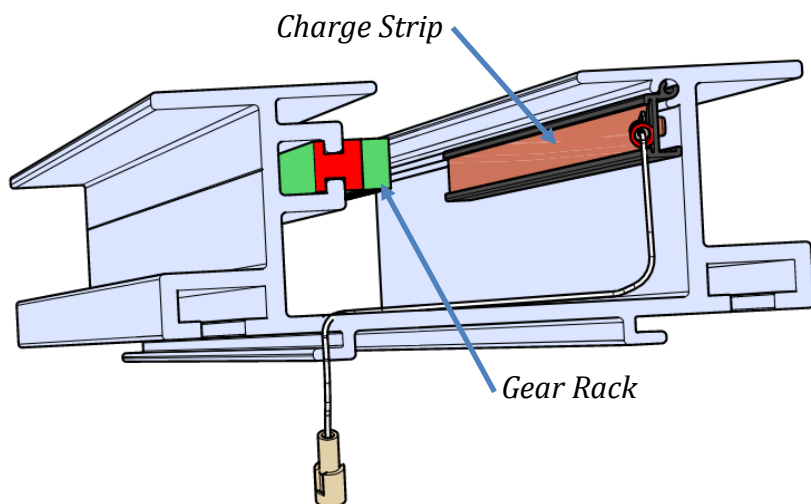
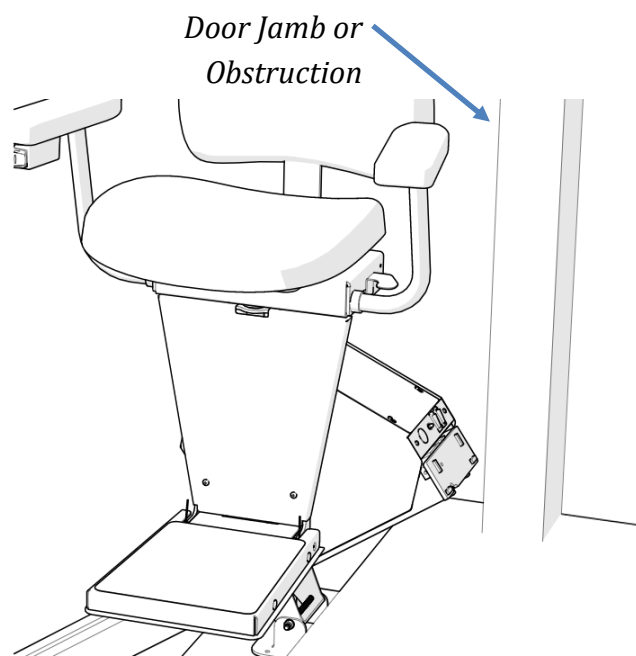

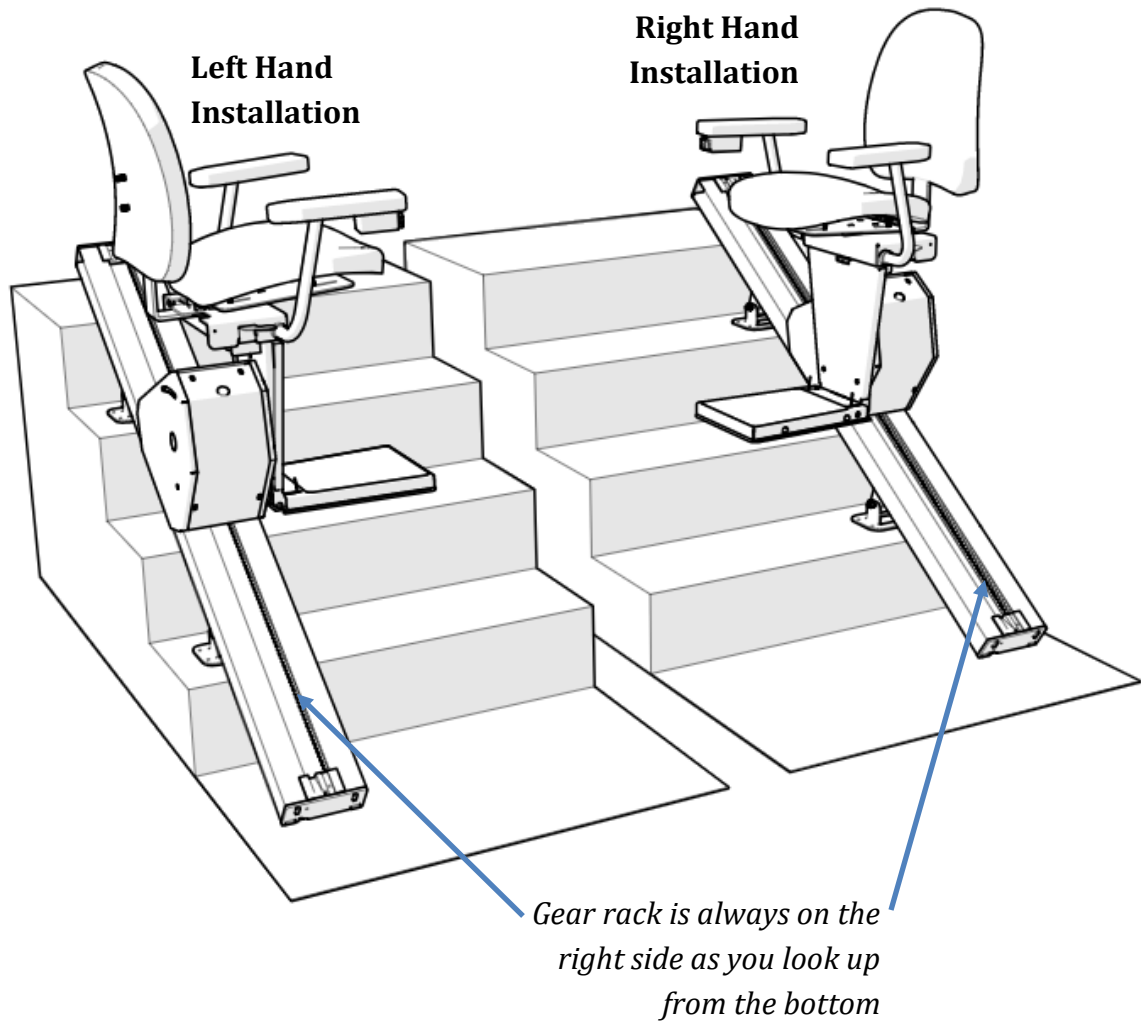

Apply a light coat of lithium grease on the gear rack and vertical sides of the track .

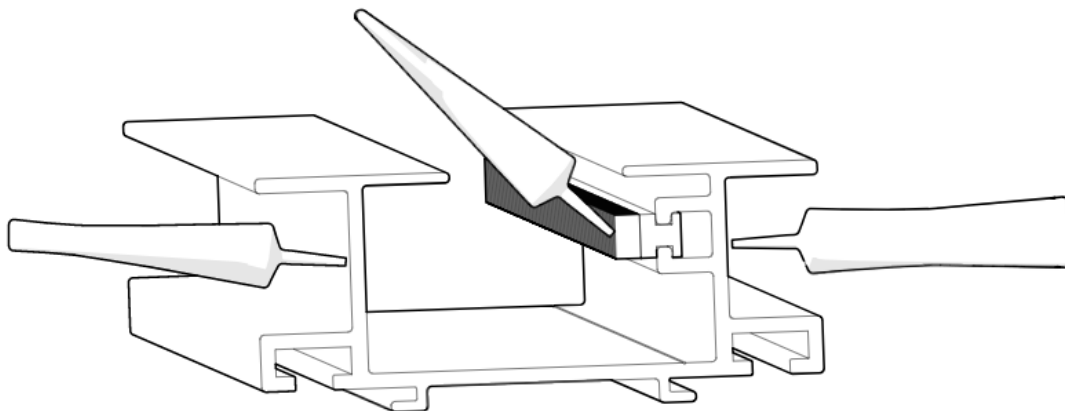

## Splice Track Pieces Together

Check the edges of the outside C-channels for rough edges. If there are any burrs, file them off before splicing the track together.

Position the splice bars so they are half way inserted into one track.

Tighten the set screws in the bars.

Tap the large end of the 3/16" pin half way into one of the tracks.

Slide the other track onto the splice ensuring that the track pieces align on all sides.

Tighten the remaining set screws to lock everything together. Run your finger over the outer edges of the tracks to assure there are no significant edges protruding. If there are, separate the track slightly and realign as required to obtain a smooth transition between the track channels.

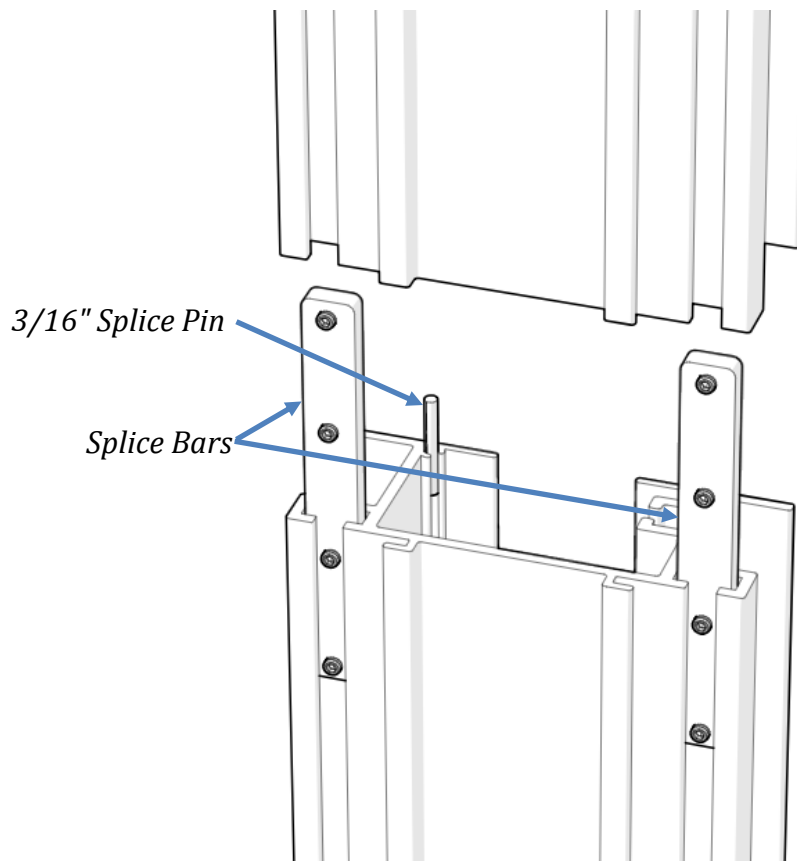



## Secure the Track to the Stair Treads

When the track is installed, there should be a 1" gap between the underside of the track and the stair nosings and 1/4" to 1/2" off the lower landing floor. The track should be at least 4" away from the wall or other obstruction.

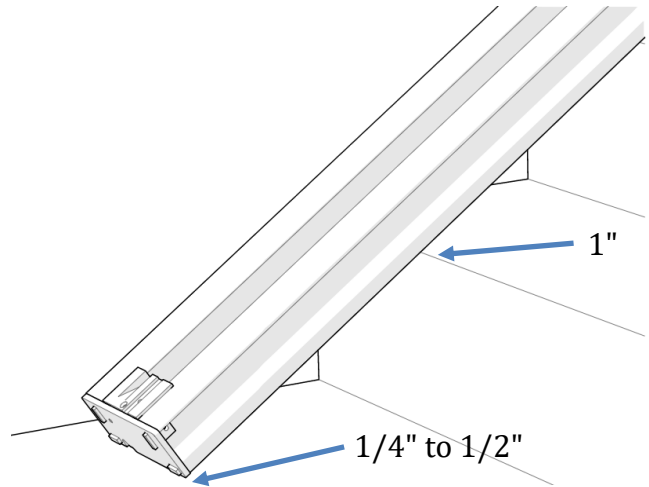

Install rail brackets by loosening the screws and snapping each bracket edge into the slot or slide the brackets on from the top of the rail. The rail brackets are designed to lean the track toward the wall to offset the weight of the unit and user, therefore, the nuts on brackets should be on the staircase side (toward the middle of the staircase).

Place one bracket on first tread, one on the top tread, and one bracket immediately above and below each splice. Then use the other brackets to support any section of track left unsupported and measuring greater than 48\".

Fasten each bracket to the treads with (4) #14 X 2" hex head lag screws.

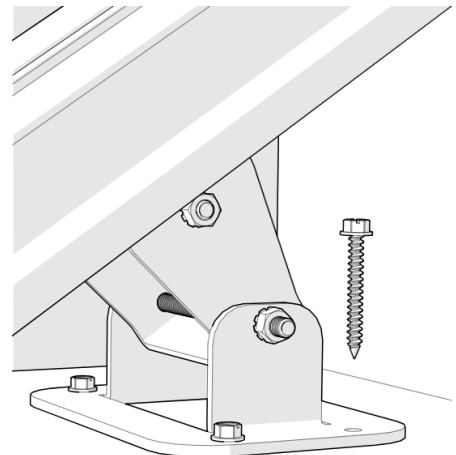
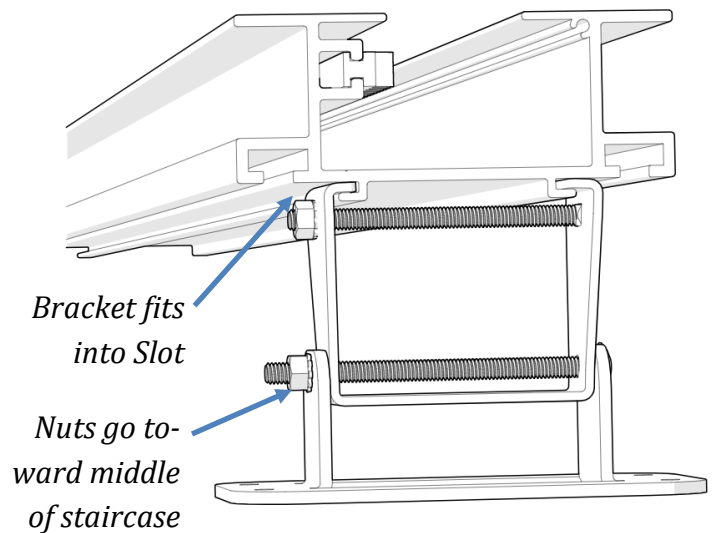

## Insert the Chassis into the Track

Remove the end plate and limit cam from the top end of the track. It is held on by set screws from the bottom and sides.

Remove the upper most section of gear rack to allow you to slide the chassis into the track easily.

Remove any tape or packing material that hold the glide blocks on the chassis axles.

The chassis can now be inserted into the top end of the track.

Loosen the four screws on top of the chassis to remove the access panel and connect the black negative battery wire to the negative terminal of the battery.

Flip the red RESET/OFF switch to the RESET position. The lift will beep and the LED indicator will turn red-yellow-green. The chassis is now ready to be run down onto the gear rack using the black INSTALLATION SWITCH on top of the chassis.

Run the chassis down the track to the lower limit.

Replace the top piece of gear rack in the track.

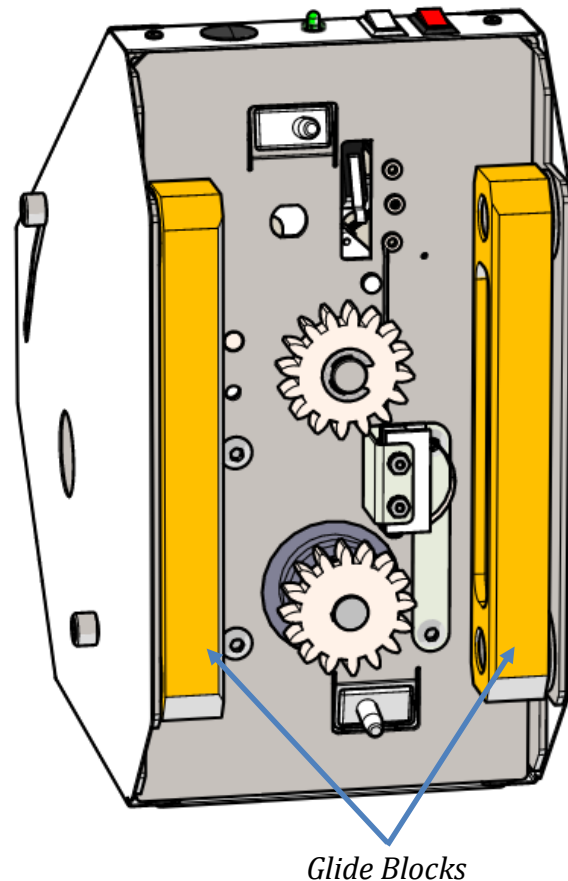

## Setup Charging System

If you cut your track at the top, slide the charge strip to where the ends of the track and charge strip are flush. Secure with a #4 x 3/8" sheet metal screw.

### Caution

The battery charger is not weather resistant. If installing outdoors, we recommend that the charger be placed inside a weather tight enclosure.

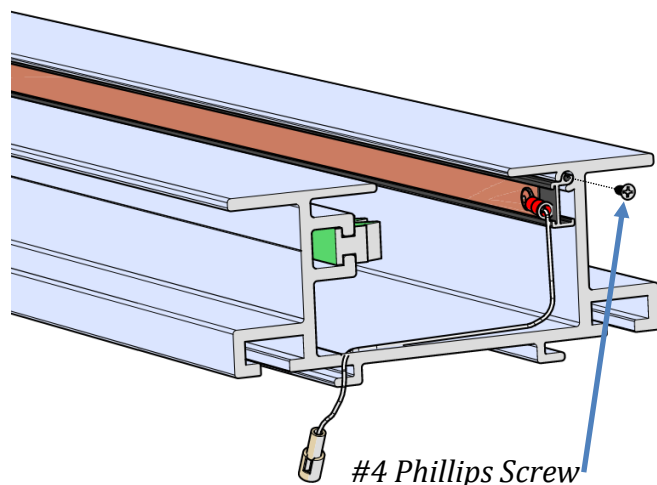

Place the upper limit cam inside the track and secure by tightening the phillips head screw.

Place the end plate onto the end of the track while routing the charge wire through the slot in the bottom of the end plate. Tighten the set screws in the end plate.

Place the end cap onto the end plate and secure with adhesive back tape.

Insert the gear rack compression screw and tighten to compress the gear rack pieces together. The screw must make contact with the gear rack. If the screw is too short, there is a longer one with the small parts.

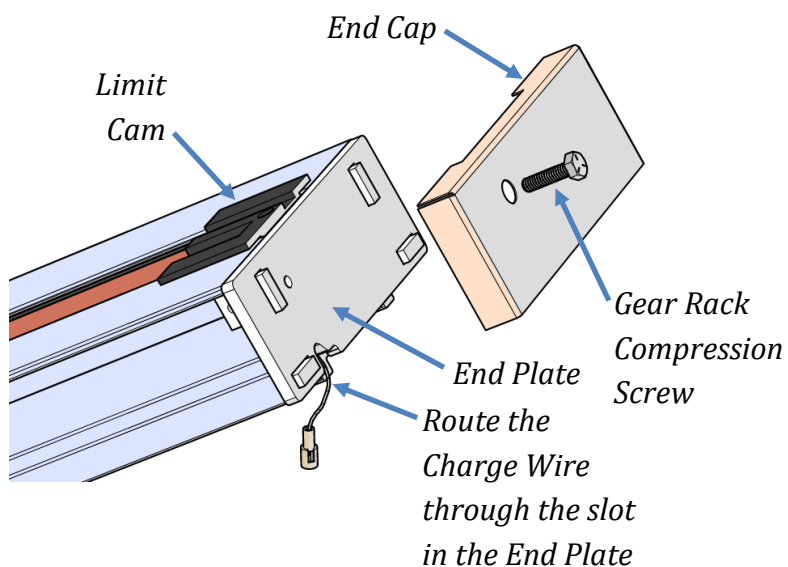

The battery charger can be placed at the top or bottom of the track. *The illustration shows the charger being at the top end of the track.*

Connect the short white wire to the mating connector from the top charge strip.

Route the long white wire to the bottom of the track and connect it to the mating connector from the bottom charge strip. *Adhesive back U-clips are provided to be applied to the bottom of the track for wire routing.*

Remove the hex head screw and star lock washer from the bottom of the end plate and connect the black wire to the end plate. Connect the harness to the charger.

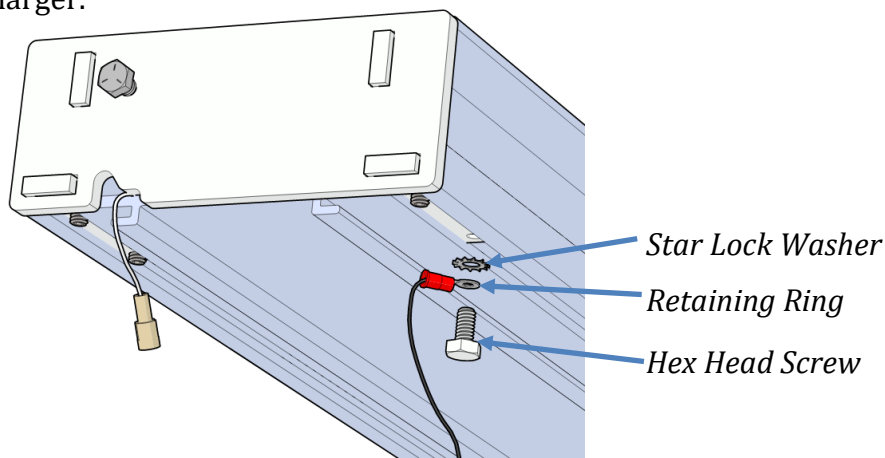
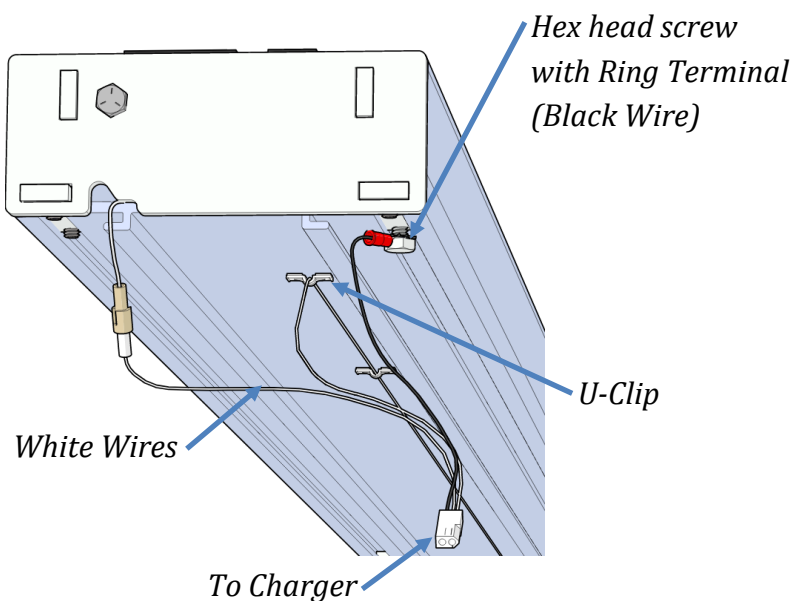

Plug the charger into 120V outlet.

## Attach Footrest

Loosen the (4) socket head screws on the sides of the chassis (2 on each side).

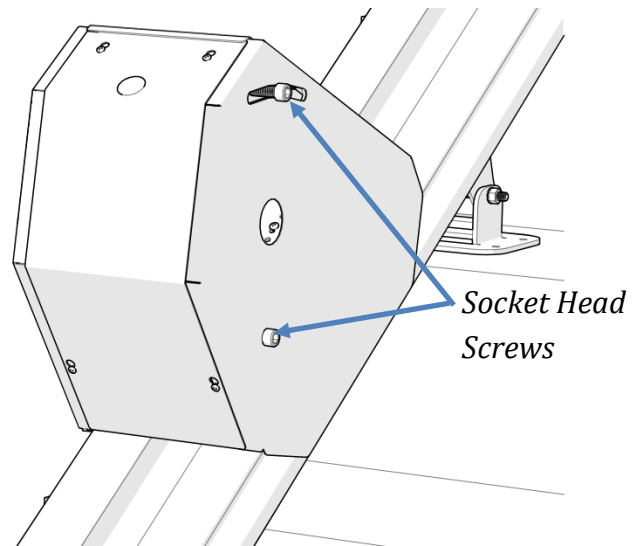

Temporarily remove the front cover from the footrest assembly (two phillips head screws).

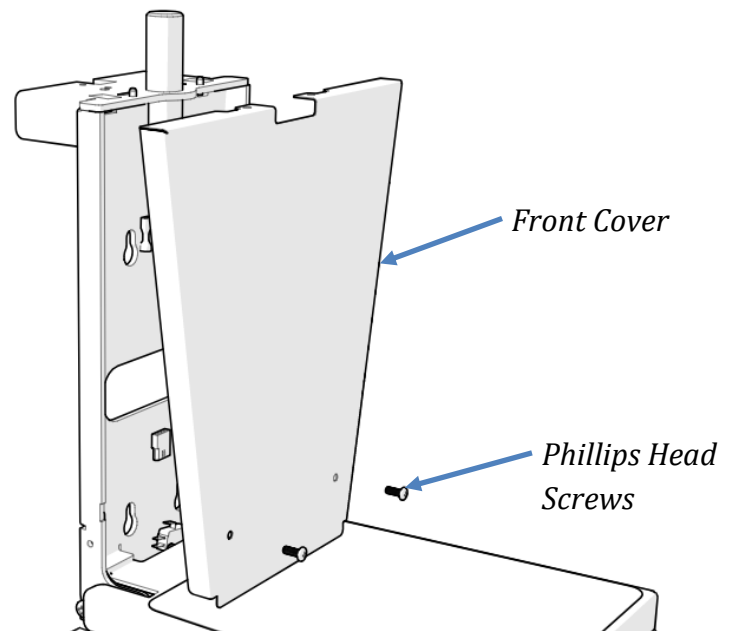

Place the footrest assembly onto the two socket head screws on the chassis. Use the keyhole pattern that offsets the footrest assembly toward the top end of the chassis.

Connect the wire harnesses between the chassis and footrest assembly.

Level the footrest and tighten the (4) socket head screws (2 in front and 2 on back). *Note that the ETL listing is valid only when the track installed at maximum angle of 45°.*

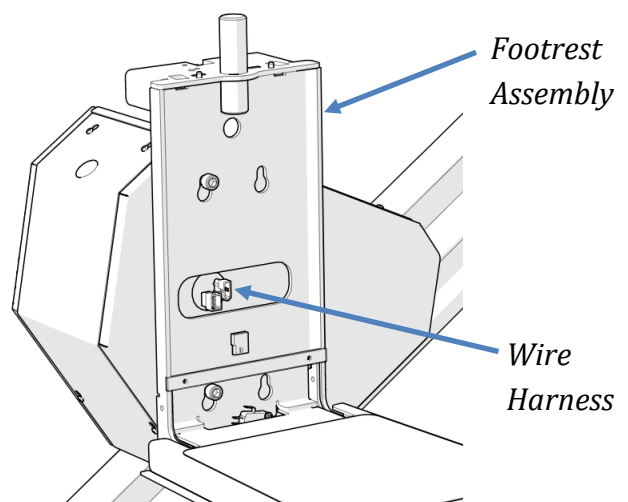

## Connect Wireless Receiver

Connect the wire harness from the RF wireless receiver to the mating connector on the backside of the chassis. Tuck the excess wiring into the opening in the chassis and mount the RF receiver to the chassis with the adhesive foam tape.

Adjust the position of the antennae as necessary.

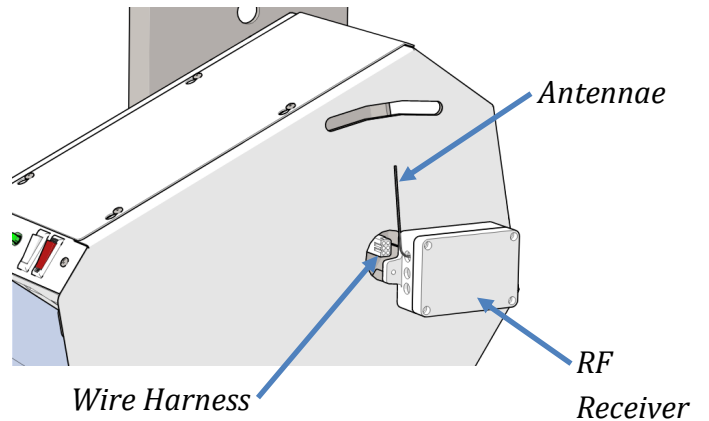

## Attach Seat

The swivel stop is factory set for a left-hand unit. If the lift is installed on the right-hand side of the staircase, move the seat swivel stop screw to the opposite hole on top of the footrest assembly.

Place the plastic thrust washer onto the swivel pin.

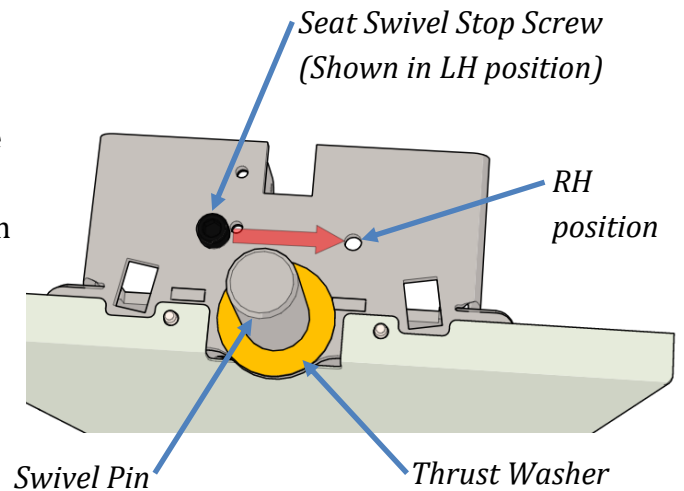

Place the seat assembly onto the swivel pin. It may be necessary to lubricate the swivel pin.

Verify the seat swivels the proper direction.

Route the wire harness from the seat control through the hole in the back of the footrest vertical plate and connect to the mating connector.

Replace the front cover on the footrest assembly.

Turn on the red RESET/OFF switch to power up the chassis located on the top of chassis.

The lift can now be operated by the unit control and the wireless key fobs.

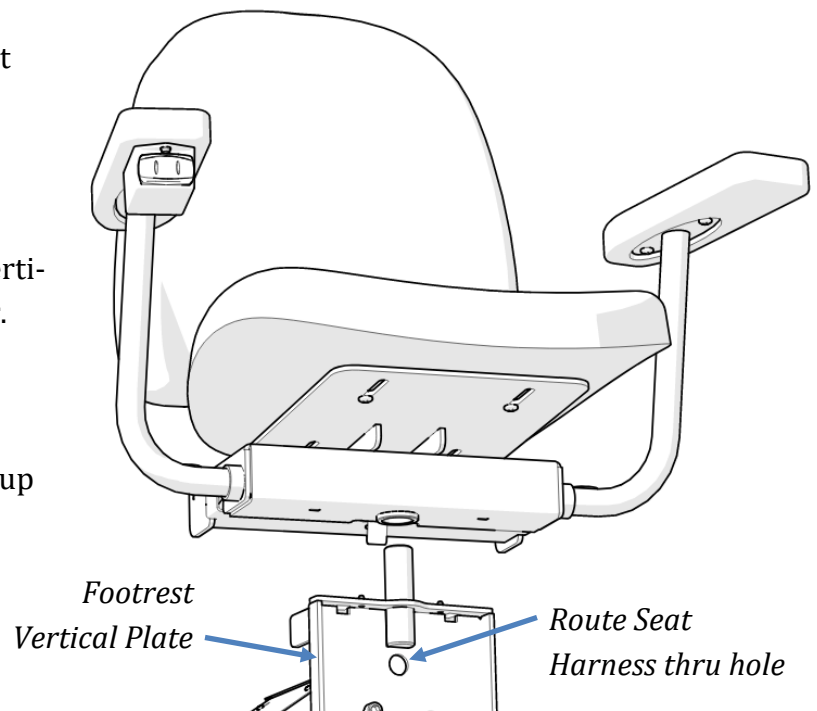

## RF Remote Call-Send Controls

The two key fobs (transmitters) have been factory programmed.

If you are installing two lifts in the same home, it is not necessary to change the program. However, two lifts cannot be operated from the remote fobs at the same time. Each transmitter and receiver is unique and has its own rolling code.

If a key fob needs to be programmed:

1. Press the program button on the RF receiver 5 times until the letter **A** is displayed. There should now be a slow flashing dot on the display.
2. Press and hold either button on one of the transmitters and then release when the dot flashes faster.
3. Repeat step 2 for each additional transmitter.

After the last transmitter is programmed, the LED display will go off and the transmitters can be tested.

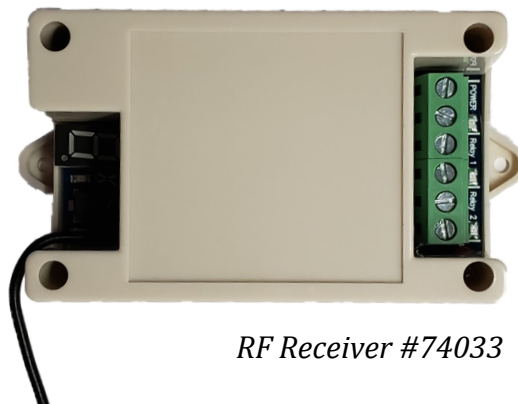

*RF Receiver #74033*

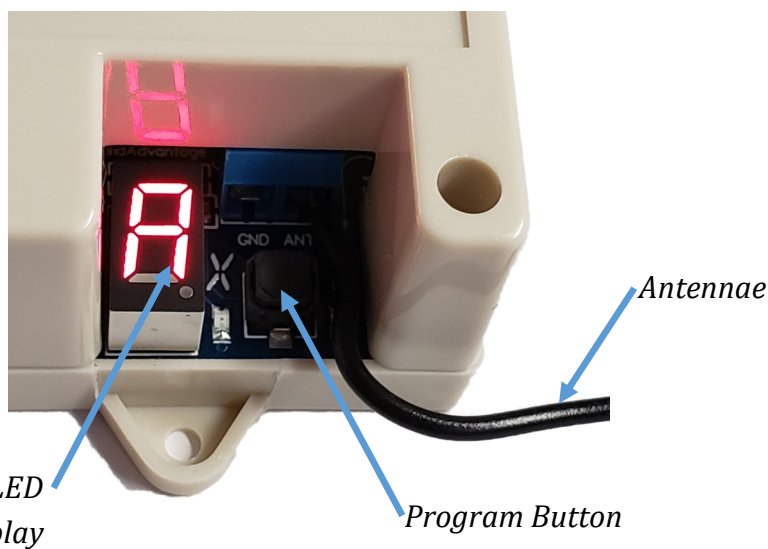

*Key Fob Transmitter #74034*

## AUDIO/VISUAL STATUS INDICATIONS

The lift is equipped with a chassis mounted 3-color LED display light to indicate the operating condition of the lift. Accompanying this is an audible alarm that will sound accordingly.

STATUS LIGHT	AUDIBLE ALARM	CONDITION
RED-YELLOW-GREEN	1 Second beep	Power-up Cycle
SOLID GREEN	None	Ready to Operate
YELLOW BLINK	1/4 Second beep (30 Seconds)	Batteries are not being charged (Beeping repeats every 10 minutes )
YELLOW PULSE	1/2 Second beep (5 Minutes)	Low Battery Voltage (under 22.5 volts)
2 YELLOW FLASHES	1/2 Second beep	Seat Swivel Latch Sensor
3 YELLOW FLASHES	1/2 Second beep	Footrest Obstruction Sensor
2 RED FLASHES*	3 Second beep	Sensor Fault (2 or more sensors engaged)
3 RED FLASHES*	3 Second beep	Final Limit
4 RED FLASHES*	3 Second beep	Travel Timeout (Motor running for more than 2-1/2 minutes)
5 RED FLASHES*		Overspeed Governor Set
YELLOW SOLID (30 SECONDS)	1/2 Second beep (30 Seconds)	Overload (Over 22 amps for 3 seconds)
RED SOLID (3 SECONDS)	3 Second beep	Key turned off while traveling( Optional)
OFF (SLEEP)*	None	Very Low Battery Voltage (Under 20.5 Volts for 5 minutes)

FLASH = 2 per second

BLINK = 1 per second

PULSE = 1 per 10 seconds

\*Requires power to be cycled OFF/ON.

# Completion Procedures

**SERVICE LINE 877.378.4275**

**(Mon-Fri 8:00 – 5:00 CST)**

## Completion Checklist

The following features must be verified as operational before the stair lift can be released for use:

- \_\_\_\_\_ **Upper and lower limits:** Verify the lift stops automatically at the top and bottom of the track.
- \_\_\_\_\_ **Charger:** Verify that the light on the charger changes from green to amber when the lift is running.
- \_\_\_\_\_ **Running Clearance:** Verify the lift clears all obstructions.
- \_\_\_\_\_ **Unit Control:** Verify control functions in both directions.
- \_\_\_\_\_ **Call/Send Remotes:** Verify both call/send controls operate the lift up and down in the appropriate direction.

### Track:

- \_\_\_\_\_ **Important: Top Track End Plate:** It is imperative the 6 small set screws under the top track end plate are very tight.
- \_\_\_\_\_ **Important: Lower Track End Plate:** It is imperative the 6 small set screws under the lower track end plate are very tight.
- \_\_\_\_\_ **Track Mounting Brackets:** Verify all track mounting brackets are securely attached to the stair treads, the track and at the pivot points.
- \_\_\_\_\_ **Track Splice:** Verify track joints are smooth and free of burrs and gaps.
- \_\_\_\_\_ Verify the rack tension screw is tight.
- \_\_\_\_\_ Verify chassis gear and rack is tight and no excess play.
- \_\_\_\_\_ **Verify the gear rack is lubricated with lithium or other all-purpose grease** (tube of lubricant is provided)
- \_\_\_\_\_ Verify the top track cover is securely fastened to the track.
- \_\_\_\_\_ Verify the inside of the track is free of foreign objects.

### Footrest:

- \_\_\_\_\_ Verify the footrest is level.
- \_\_\_\_\_ Verify the footrest clears all stair nose.
- \_\_\_\_\_ Verify the lift stops when the footrest runs into an obstruction in the up direction.
- \_\_\_\_\_ Verify the lift will run down while the footrest is obstructed.
- \_\_\_\_\_ Verify the footrest folds up and stays in the up position.

### Seat:

- \_\_\_\_\_ Verify the seat is level and securely fastened.
- \_\_\_\_\_ Verify seatbelt & buckle are secure and function.
- \_\_\_\_\_ Verify the seat swivels toward the upper landing and locks into position.
- \_\_\_\_\_ Verify the lift will not operate when the seat is not locked in the riding position.
- \_\_\_\_\_ Verify the seat will fold up and stay in the up position.
- \_\_\_\_\_ Verify both arms will fold up and stay in the up position.
- \_\_\_\_\_ **Clean Up:** Verify the stair lift has all grease, dirt, etc. cleaned off.

### Before leaving the jobsite:

- \_\_\_\_\_ Clean up work area.
- \_\_\_\_\_ Assist customer on how to use the unit and ride it properly.
- \_\_\_\_\_ Demonstrate proper operation, seatbelt use, lubrication and maintenance procedures to the user of the lift and other family members at the residence.
- \_\_\_\_\_ Give customer a copy of the Owner's Manual for reference. Please take time to insert your business card or write your company name, address and telephone number inside the Owner's Manual in the area provided.



